

BURNER MOUNTING CAGES

SERIES BCA, BCB, BCC

MODEL: 5770-BCA, 5770-BCB,
5770-BCC

Revision: 0

BULLETIN
5770

DESCRIPTION

Burner Mounting Cages are designed to simplify attaching burners to furnace walls, air heaters, kilns, boilers or other combustion chambers. They are simply but substantially built, providing considerable flexibility of adjustment and burner location.

The burner nozzle, not a part of the cage, is held in place by its supply pipe running through the back of the cage. Slotted head set screws, which can be tightened with a screwdriver, are provided for locking the burner nozzle in position after it has been correctly located with relation to the burner opening.

All cages have two tapped openings for pilot, protective device or peep sight mounting. These tapings have been worked out so that the pilot flame and protective device element, if used, will intersect at the main burner flame. Either atmospheric or blast type pilots may be applied to mounting cages.

The smaller cages, Style A, have single piece bodies with secondary air shutters opening away from the appliance. After the proper secondary air setting has been determined, the shutter may be locked in place with the thumb nut.

The larger cages, Style B, have two-piece bodies with rotating secondary air shutters. This arrangement permits removing the burner, by taking off the backplate of the cage, without removing the cage body from the furnace wall or appliance. Also, this design makes it unnecessary to remove or disturb pilot or protective equipment mounted on the cage. This simplifies changing damaged or overheated burner nozzles.

All sizes of Burner Mounting Cages are especially designed for compactness, simplicity, and ease of service in the field. Ample secondary air flow, flexibility of installation, and ease of burner maintenance are "built-in" features of these cages.



20 BCB Style Mounting Cage



**# 10 TA Cage Torch Burner
with Style A Cage**



**# 24 ETB Elbow Cage Torch
with Style B Cage**

CAUTION: Operation of combustion equipment can be hazardous resulting in bodily injury or equipment damage. Each burner should be supervised by a combustion safeguard and only qualified personnel should install, make system adjustments and perform any required service.



pyronics inc.

COMBUSTION FOR INDUSTRY

17700 MILES ROAD
CLEVELAND, OH 44128
www.pyronics.com

Tel: 216-662-8800
Fax: 216-663-8954
marketing@pyronics.com

NOTICE: PYRONICS practices a policy of continuous improvement in the design of its products. It reserves the right to change the specifications at any time without prior notice.

BURNER MOUNTING CAGES

SERIES BCA, BCB, BCC

BULLETIN 5770
PAGE NO. 2

DIMENSIONS - BCA AND BCB SERIES

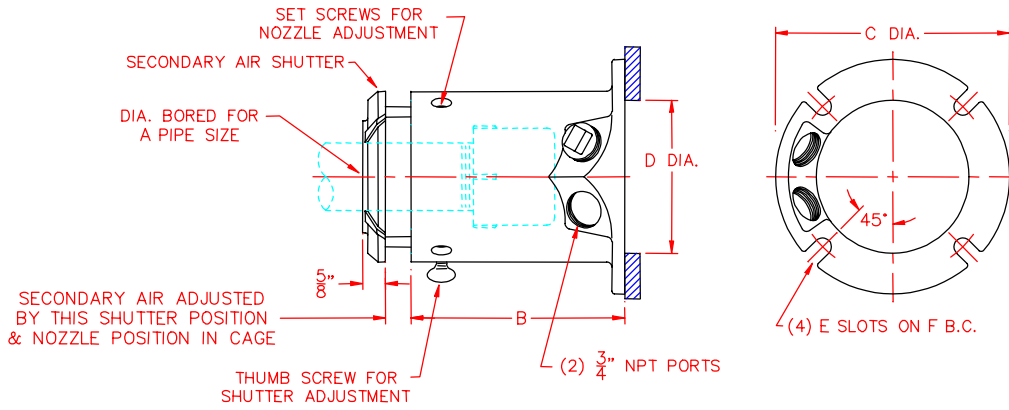

10 BCA AND 12 BCA CAGES

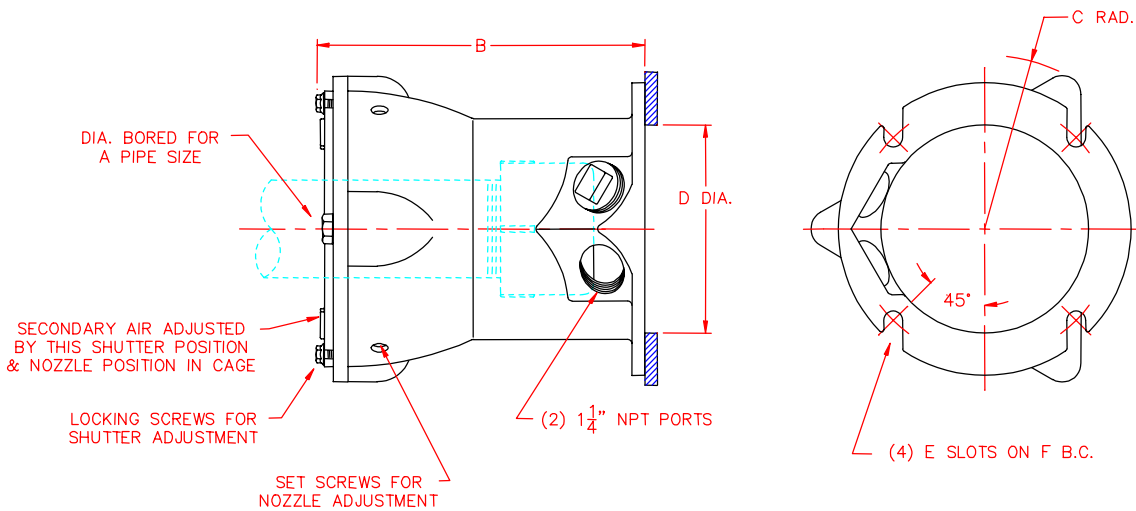

12 BCB TO 48 BCB CAGES

Model Number	Cage Style	A	B	C	D	E	F	Weight	
								Lbs.	Kgs.
10-BCA	A	1-1/4"	5-1/4"	5-3/4"	3-3/4"	7/16"	4-7/8"	4	1.8
12-BCA	A	1-1/2"	5-1/4"	5-3/4"	3-3/4"	7/16"	4-7/8"	4	1.8
12-BCB	B	1-1/2"	6-3/4"	4-1/4"	4-1/2"	9/16"	6"	10	4.5
16-BCB	B	2"	6-3/4"	4-1/4"	4-1/2"	9/16"	6"	10	4.5
20-BCB	B	2-1/2"	9-5/8"	5-1/8"	6-1/8"	9/16"	7-5/8"	11	5.0
24-BCB	B	3"	9-5/8"	5-1/8"	6-1/8"	9/16"	7-5/8"	11	5.0
32-BCB	B	4"	10-5/8"	7-1/8"	8-1/4"	5/8"	9-3/4"	20	9.1
48-BCB	B	6"	11-1/4"	8-1/4"	9-1/2"	5/8"	11-3/4"	27	12.2

BURNER MOUNTING CAGES

SERIES BCA, BCB, BCC

BULLETIN 5770
PAGE NO.3

DIMENSIONS - BCC SERIES

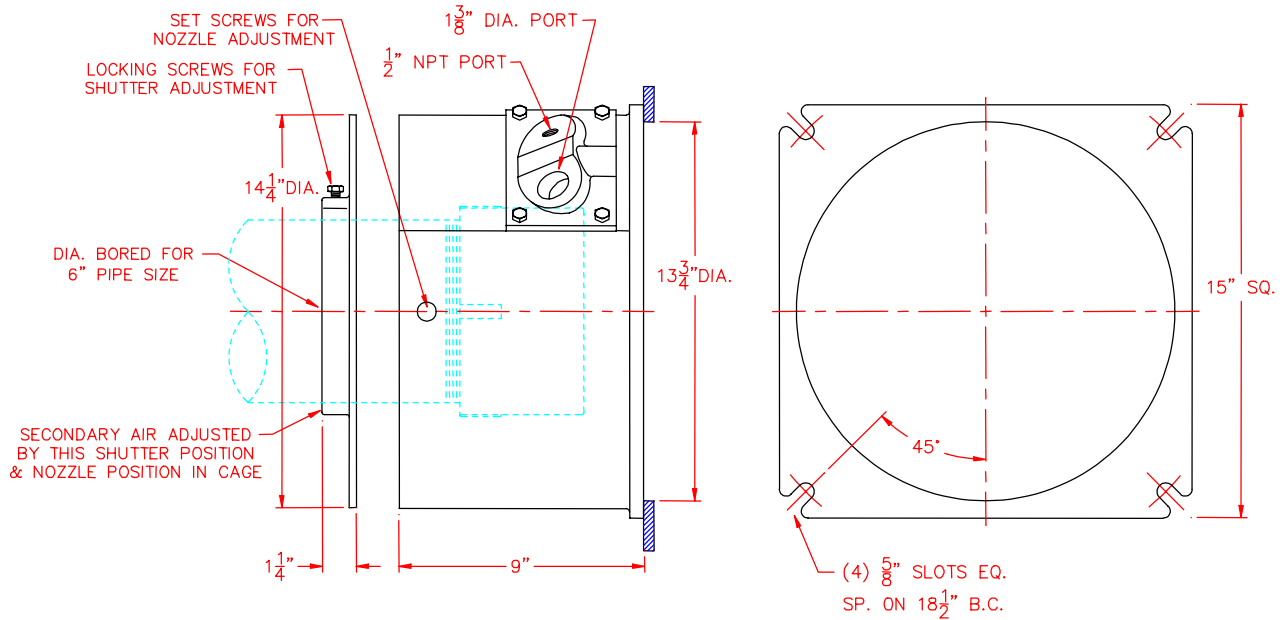

48 BCC CAGE (WEIGHT 69 LBS.)

USED WITH			USED ON		
Cage Model Number	Burners		Standard and Medium Pressure Series Torches	High Pressure Torches	Hi-Lo Torches
	A.N.	F.R.			
10 BCA	10	10	10 & 100 RTA	1000 RTA	
12 BCA	12		12 & 120 RTA		
12 BCB	12	12	12 & 120 RTB	1200 RTB	12 HLT
16 BCB		16		1600 RTB	
16 BCB	16		16 & 160 RTB		16 HLT
20 BCB		20		2000 RTB	
24 BCB		24		2400 RTB	
20 BCB	20		20 & 200 RTB		20 HLT
24 BCB	24		24 & 240 RTB		24 HLT
32 BCB		32		3200 RTB	
32 BCB	32		32 & 320 RTB		32 HLT
48 BCB		48		4800 RTB	
48 BCC	48		48 & 480 RTB		48 HLT

ORDERING INFORMATION

Please include the following information with your order:

1. Specify Model Number and Quantity of each size Burner Mounting Cage.
2. Shipping Instructions.

CAUTION: Operation of combustion equipment can be hazardous resulting in bodily injury or equipment damage. Each burner should be supervised by a combustion safeguard and only qualified personnel should install, make system adjustments and perform any required service.



pyronics inc.

COMBUSTION FOR INDUSTRY
17700 MILES ROAD
CLEVELAND, OH 44128
www.pyronics.com

Tel: 216-662-8800
Fax: 216-663-8954
marketing@pyronics.com

NOTICE: PYRONICS practices a policy of continuous improvement in the design of its products. It reserves the right to change the specifications at any time without prior notice.